

DATENBLATT / DATA SHEET

SMA-Buchse crimp / SMA socket crimp

Artikel-Nr. / Part no.: 7751



www.ssb-electronic.de

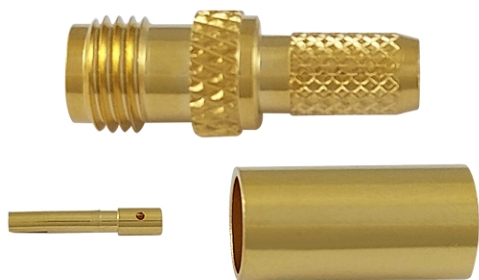

Das Produkt kann von der Abbildung abweichen. /
The product may differ from the illustration.

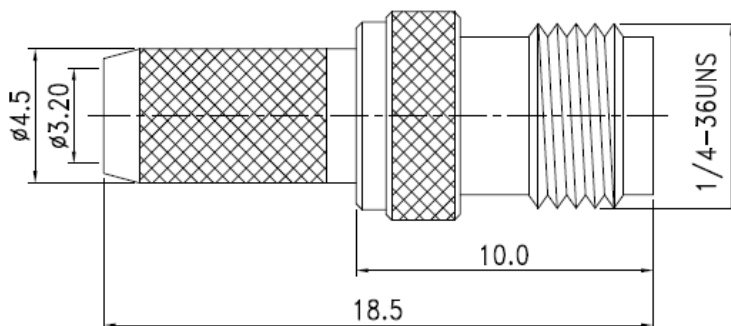

Alle Angaben in mm / All dimensions are in mm

Norm: IEC 60 169-15 Steckertyp: SMA-Buchse crimp

Connector type: SMA socket female crimp

Kabeltypen / Cable types: Aircell 5

Mechanische Eigenschaften / Mechanical specifications:

Lebensdauer (Steckungen) / Life time (plug cycles)	500
Verbindergehäuse / Body	Messing vergoldet / Brass gold plated
Isolierhülse / Insulation	PTFE
Pin	Phosphorbronze vergoldet / Phosphor bronze gold plated
Hülse / Ferrule	Messing vergoldet / Brass gold plated
Temperaturbereich / Operating temperature	-40°C / +155°C
Gewicht / Weight	2,9 g
RoHS konform / RoHS compliant	Ja / Yes
Empfohlene Crimp-Werkzeug-Größe / Recommended crimping tool size	5,41 mm

Elektrische Eigenschaften / Electrical specifications:

Betriebsspannung / Working voltage	≤ 480 V rms
Impedanz / Impedance	50 Ω
Isolationswiderstand / Insulation resistance	5 GΩ
Frequenz bis zu / Frequency up to	8 GHz
VSWR	≤ 1,20
Durchgangswiderstand innen / Inner contact resistance	≤ 3,0 mΩ
Durchgangswiderstand außen / Outer contact resistance	≤ 2,0 mΩ

Technische Änderungen vorbehalten / Right of technical modification is reserved

SSB-Electronic GmbH · Am Pulverhäuschen 4 · 59557 Lippstadt · Germany

DB-079-00_7751_DE/EN

Stand/status: November 2024