

# Data sheet / instructions for use



## LNA 200 MA Art.No.:1011-MA



### Product description

The LNA 200 MA is a selective receiving preamplifier that is built into a mast housing. With a super low noise figure and high gain, it also offers very high large-signal immunity. This amplifier is built with a GaAs MMIC of the latest technology on a high-quality microwave substrate in SMD technology and is unconditionally stable (k factor less than 1 up to 10 GHz). The input circuit of the amplifier is built with HQ components in a chamber design and optimized for the best possible noise properties. The band pass at the output of the amplifier ensures a good band selection so that all signals that are outside the useful band are effectively suppressed. The LNA 200 MA is used in transmitting / receiving systems together with the AS-3000 switch (split operation). It is ideal for EME, Meteorscatter, Aurora, Troposcatter and contest operations.

### Technical specifications

Frequency range:	144-146 MHz
Noise figure: @ 20°C:	0,5 dB
Gain, typ.:	22 dB
Return loss:	
Input:	22 dB
Output:	22 dB
OIP3:	35 dBm
IIP3:	14 dBm
Max. Input level:	20 dBm
Operating voltage:	8-14 V
Current consumption:	110 mA
Housing dimensions:	108x59x84 mm
Weight:	140 g
Connection standard:	N-female

### Connection notes

In systems that are only intended for reception, the preamplifier is fed remotely via the coaxial output line from the antenna input of the receiver. For receivers that do not have an LNA power supply at the antenna input, a DC

splitter, e.g. DCC 5000 pro, must be connected upstream of the antenna input of the receiver. When using the AS-3000 switch (split operation), this preamplifier is supplied with voltage from the sequencer via the coaxial output line of the preamplifier.

Examples of the wiring of systems using the LNA 200 MA are shown in the block diagrams.

**Attention!** The LNA 200 MA does not have a send / receive switchover. Excessive signal levels at the input or output of the amplifier can damage the device.

### Notes on environmental protection



Electrical and electronic devices must not be disposed of with household waste. These are to be handed in at specially set up collection points or at the point of sale. Packaging materials are to be separated and disposed of with household waste according to the type of material.

### Maintenance, care

Do not open the device. The device does not contain any serviceable parts. If you need support with technical questions or in case of service, please contact us by email: [technik@ssb-electronic.de](mailto:technik@ssb-electronic.de)

### Security, warranty

The product is unsuitable for children. The packaging material and the device may contain small parts that can be swallowed.

Repairs may only be carried out by qualified personnel; however, opening the device or improper use will void any warranty claims.

There will be no guarantee. This device complies with the Low Voltage Directive 2006/95 / EC, as well as 2004/108 / EC, 2002/96 / EC, 1999/44 / E

### Declaration of Conformity



It is hereby declared that the above product complies with all regulations relevant to the product within the scope of the Council Directives 73/23 / EEC, 89/336 / EEC and 99/5 / EC.

Manufacturer: SSB-Electronic GmbH,  
Am Pulverhäuschen 4,  
59557 Lippstadt/Germany

Technical changes reserved. The contents of this document are the intellectual property of SSB-Electronic GmbH. Duplication is only permitted with express, written permission.

### Contact:

E-Mail: [technik@ssb-electronic.de](mailto:technik@ssb-electronic.de)  
Telephone: +49 (0) 2941-93385-0  
Internet: [www.ssb-electronic.de](http://www.ssb-electronic.de)

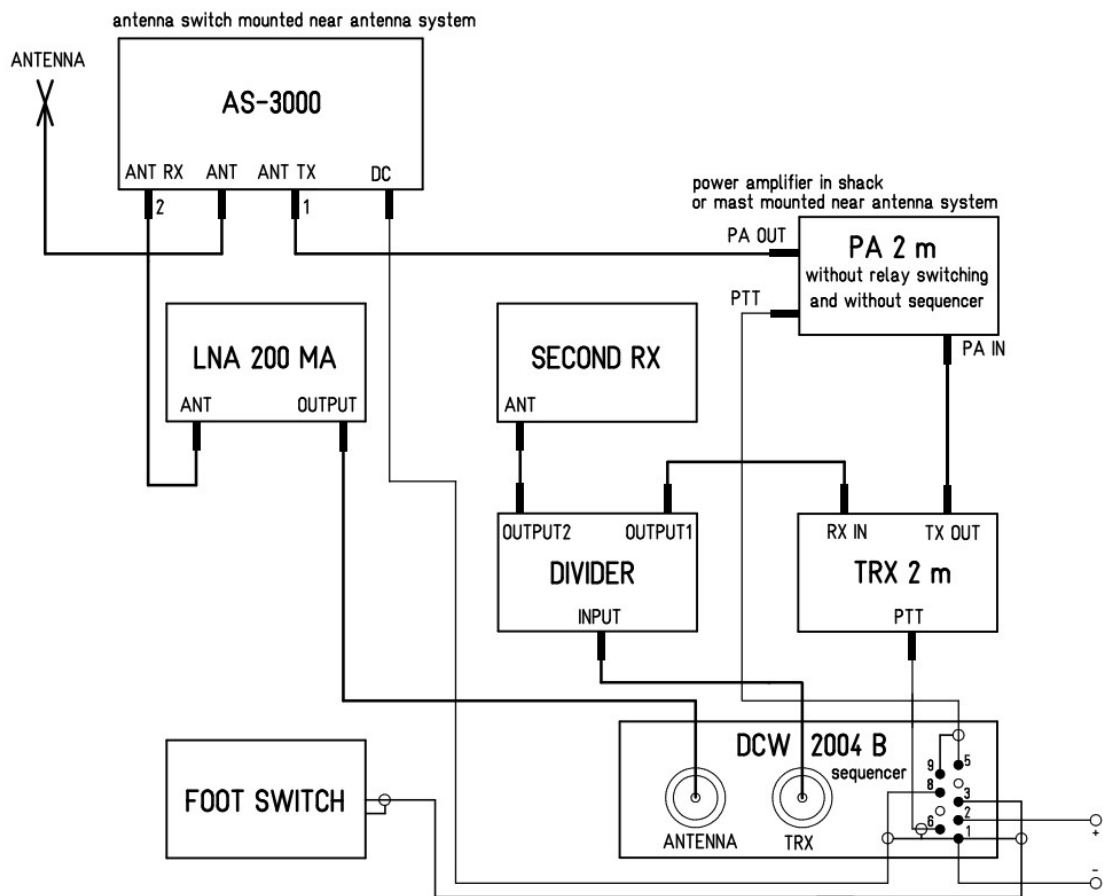

LNA 200 MA in a transmitter / receiver system with a second receiver and a power amplifier without a switchover relay.

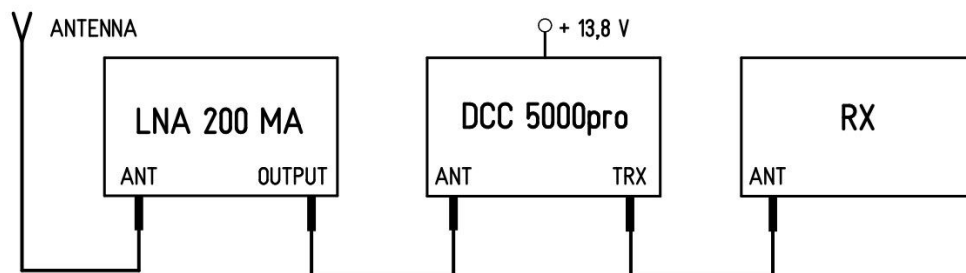

LNA 200 MA in a receiving system with remote feed via a DC voltage switch.